

ALUMERO

easySPEED 1
FLAT ROOF SYSTEM

EN

MOUNTING INSTRUCTIONS

easySPEED 1 is an aerodynamic assembly system for framed PV modules that is used to install photovoltaic panels on flat roofs.

The modules are installed at an angle of approx. 10° in east/west orientation and in south-facing orientation. They are held in place by ballast blocks and do not require drilling.

Prior to assembly, make sure that you are using the **current mounting instructions** and read these carefully before you begin. These instructions explain how to assemble the easySPEED 1 components, the modules and the ballast.

The **ALUMERO Solar.Pro.Tool** software must be used to calculate the ballast required for the easySPEED 1 assembly system. Refer to the project report prepared by your **ALUMERO** sales partner for the arrangement of the ballast blocks, the required components and their position.

This data is vital to ensure that your PV system operates safely and reliably.

ALUMERO accepts no liability for failure to observe the mounting instructions, the project statics prepared with the ALUMERO Solar.Pro.Tool or for incorrect data communicated by the customer to prepare the project report. The ALUMERO T&Cs and Warranty Conditions apply additionally.

Before starting assembly, the PV system installer must ensure that the roof substructure is suitable for the additional prevailing loads. To do so, please contact a structural engineer close to you. The compressive strength of the roof insulation and cladding as well as the coefficient of friction must be tested before starting construction. The surface and point loads of the easySPEED 1 system are stated in the project report.

A photovoltaic system requires maintenance, which is recommended on an annual basis or directly after a storm event. The position of the ballast blocks must be checked in particular.

The easySPEED 1 flat roof system is designed exclusively for mounting framed PV modules in a horizontal orientation. Any other form is considered improper use.

By default, the modules are clamped on their short side. The installer must check whether clamping on the short module side is permitted before the start of construction. This approval may be stated in the module certification. The individual module manufacturer can also be requested to issue approval for specific projects if necessary. Assembly must always be performed by qualified specialists.

Contact the professional and comprehensive ALUMERO customer care service if you have further questions.

TABLE OF CONTENTS

- General Information 3
- Components 5 - 6
- System Overview East/West 7
- System Overview South 8-9
- Assembly East/West 10-11
- Mounting Details East/West 12-13
- Alpine Variant East/West 14-15
- Assembly South 16-18
- Mounting Details South 19-20
- Alpine Variant South 21-22
- Mounting the Wind Deflector Plate 23-24
- Mounting the Ballast Tray 25-36
- Ballast 27
- Mounting the Cable Management 28
- Notes 29-31

GENERAL INFORMATION

Use:	Flat roofs
Roof inclination:	0°-5°
Roof height:	max. 25 metres
System inclination:	approx. 10°
Modules:	framed modules
Module sizes	Width: 990 - 1200 mm Length: 1650 - 2300 mm
Module orientation:	horizontal
Max. module panel size:	21 x 21 metres
Screw mounting:	M8 (A2-70)
Torque:	15 Nm

MOUNTING ON GRAVEL ROOFS

Recommendation: The gravel should be cleared so that the **easySPEED 1** plates are in direct contact with the roof covering. The removed gravel can be placed in gravel trays and reused as ballast.

The system can also be mounted directly on the gravel. A check must always be carried out to ensure that a suitable protective fleece that complies with the regulations has been installed beneath the gravel layer. However, we recommend consulting with ALUMERO about the specific project.



Please note: Kindly refer to the mounting instructions for the individual modules for the maximum load-bearing capacity of the PV modules and the approved clamping ranges.

REQUIRED TOOLS

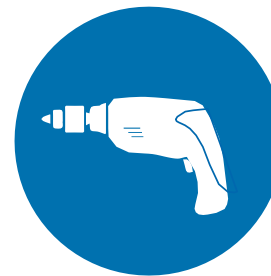

Cordless
screwdriver with
SW6 hex key socket

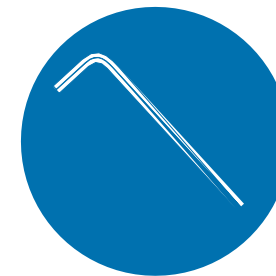

SW6 hex key

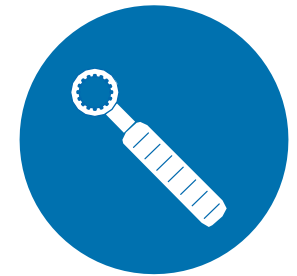

Torque wrench

COMPONENTS - SOUTH & EAST/WEST

STANDARD



Large plate 140 (700 x 140 mm)
Product number: 200201



Small plate 140 (480 x 140 mm)
Product number: 200202



Centre clamp Product number: 200301-xx



Wind deflector plate 1945
Product number: 200105-1945
Module length: 1650 - 1850 mm



Small raiser Product number: 200101



Large raiser Product number: 200102



Terminating clamp
Product number: 200304-xx

Wind deflector plate 2145
Product number: 200105-2145
Module length: 1851 - 2050 mm

Wind deflector plate 2395
Product number: 200105-2395
Module length: 2051 - 2300 mm

COMPONENTS - SOUTH & EAST/WEST

OPTIONAL



Large plate 220
(700 x 220 mm)
Product number: 200203



Small plate 220
(480 x 220 mm)
Product number: 200204



Shim
Product number: 200211



Ballast tray 2025
Product number: 200106-2025
Module length: 1650 - 1850 mm



Gravel ballast tray 2025
Product number: 200107-2025
Module length: 1650 - 1850 mm



Ballast brace 300
(up to a block width of 300 mm)
Product number: 200108



Ballast brace 400
(up to a block width of 400 mm)
Product number: 200109

Ballast tray 2225

Product number: 200106-2225
Module length: 1851 - 2050 mm

Gravel ballast tray 2225

Product number: 200107-2225
Module length: 1851 - 2050 mm

Ballast tray 2475

Product number: 200106-2475
Module length: 2051 - 2300 mm

Gravel ballast tray 2475

Product number: 200107-2475
Module length: 2051 - 2300 mm

ACCESSORIES



Cable tie incl. clip
Product number: 800706



Clip KC 1 (wind deflector plate)
Product number: 800707



Washer Product number: 823002-24



hexagon socket bolt M8x15 Product number: 800617



Small cable cover
Product number: 200402

Large cable cover

Product number: 200401

SYSTEM OVERVIEW - EAST/WEST

STANDARD:

Modules are clamped on the **short side**



ALPINE VARIANT:

Modules are clamped on the **short side** with additional **“support leg”** in the centre



ROW SPACING:

STANDARD:

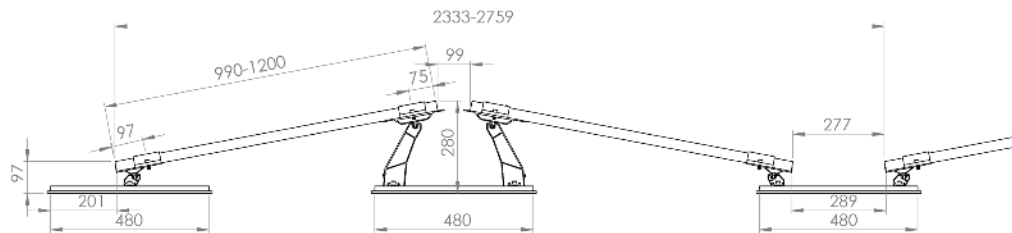

ALPINE

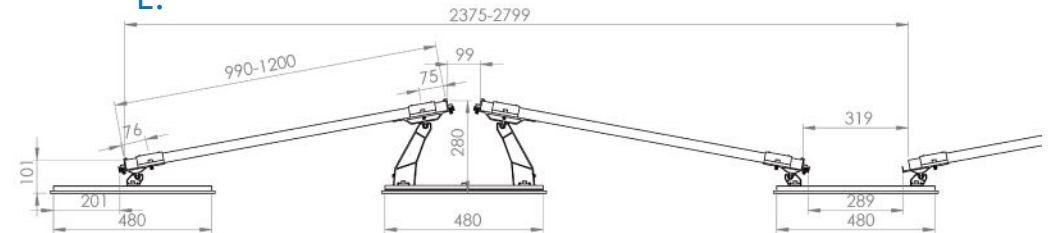

SYSTEM OVERVIEW - SOUTH 18°

STANDARD: SHADING ANGLE 18°

Modules are clamped on the **short side**

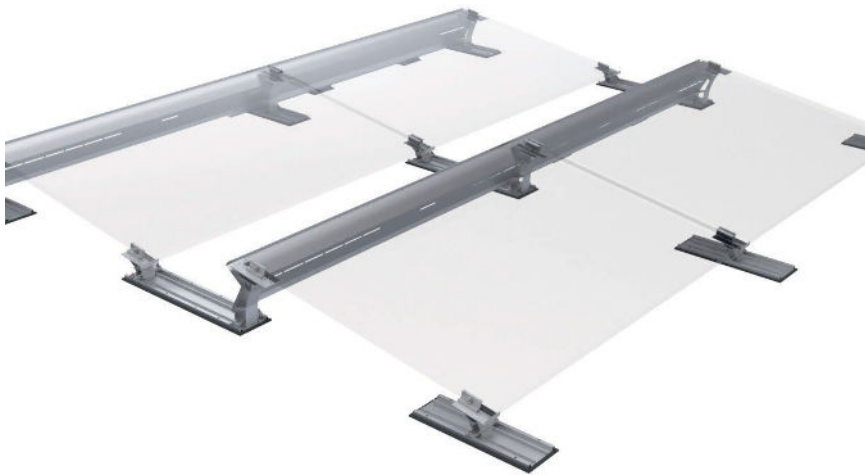

ALPINE VARIANT: SHADING ANGLE 18°

Modules are clamped on the **short side** with additional
“**support leg**” in the centre

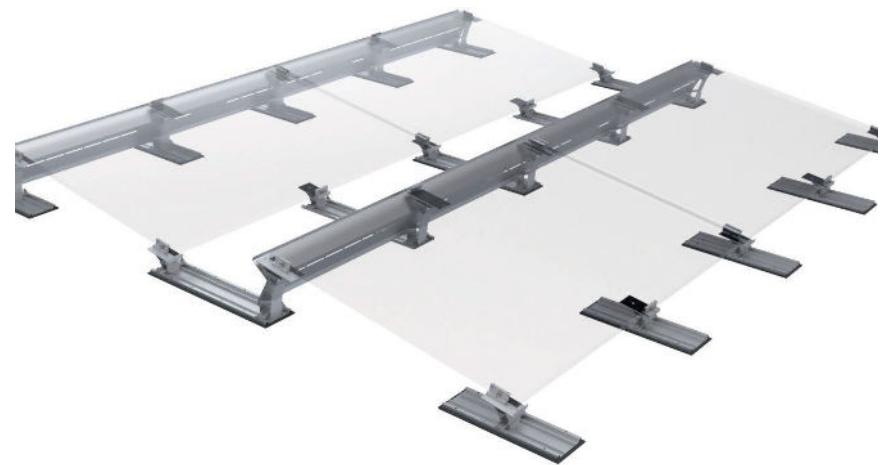

ROW SPACING:

SHADING ANGLE 18°

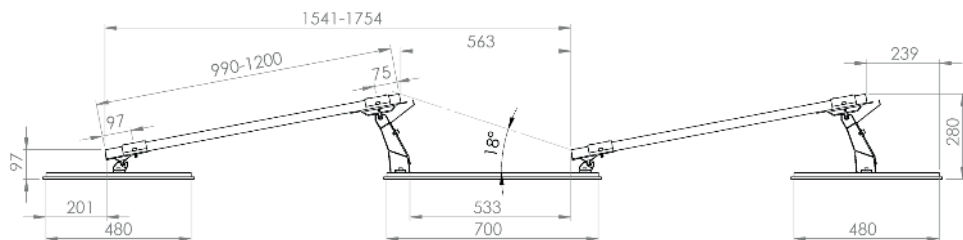

SHADING ANGLE 18° ALPINE

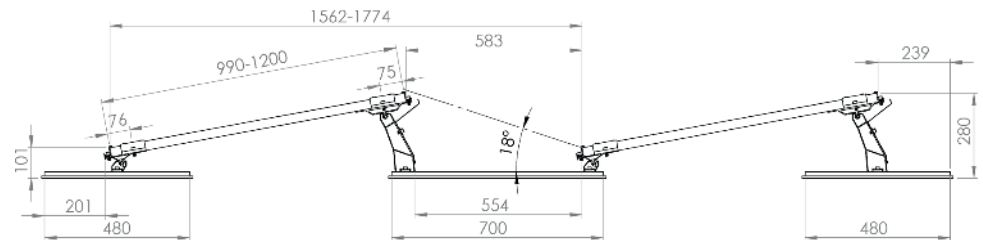

SYSTEM OVERVIEW - SOUTH 25°

STANDARD: SHADING ANGLE 25°

Modules are clamped on the **short side**

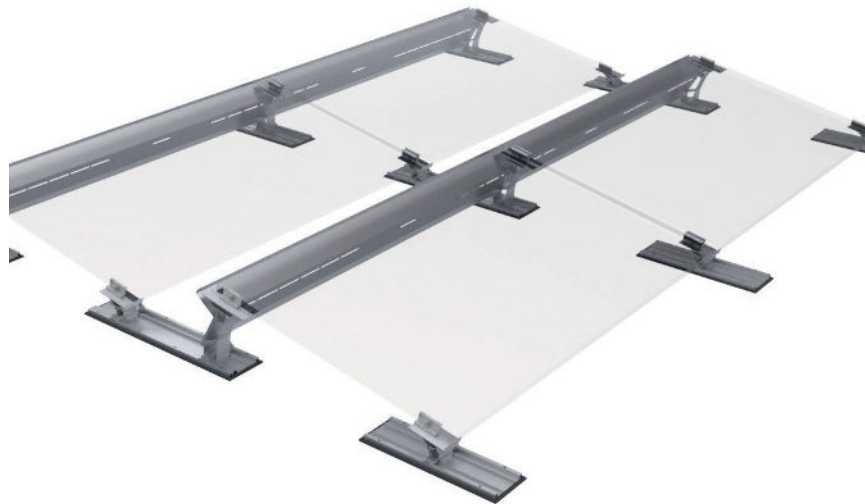

ALPINE VARIANT: SHADING ANGLE 25°

Modules are clamped on the **short side** with additional "support leg" in the centre

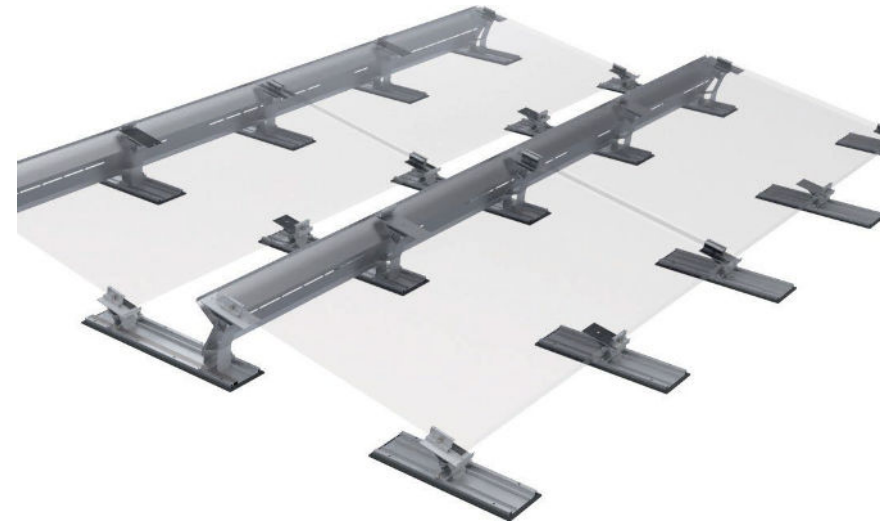

ROW SPACING:

SHADING ANGLE 25°

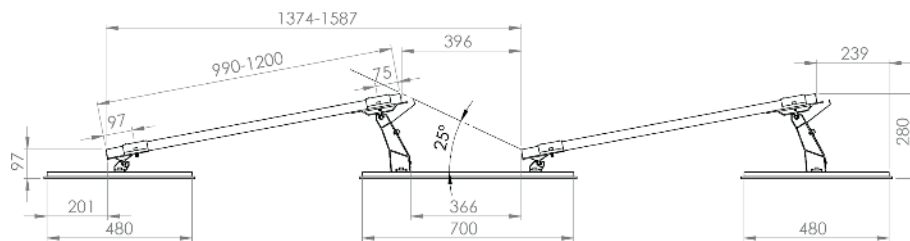

SHADING ANGLE 25° ALPINE

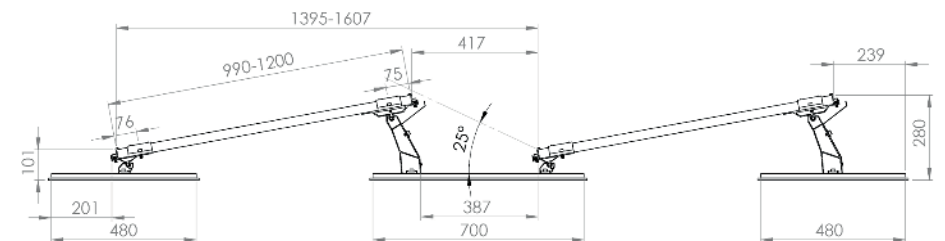

ASSEMBLY - EAST/WEST

1

FRONT LEG

Position the **small raiser** on the **central hole** in the small plate. Apply **15 Nm** to tighten the hexagon socket bolt.

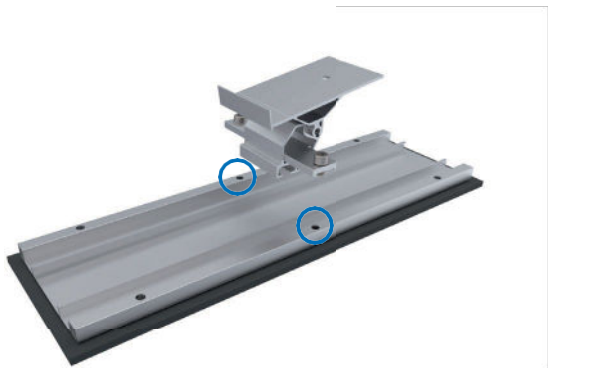

LOWERED CENTRE LEG

Position each of the **small raisers** on the **outer holes** in the small plate. Apply **15 Nm** to tighten the hexagon socket bolt.

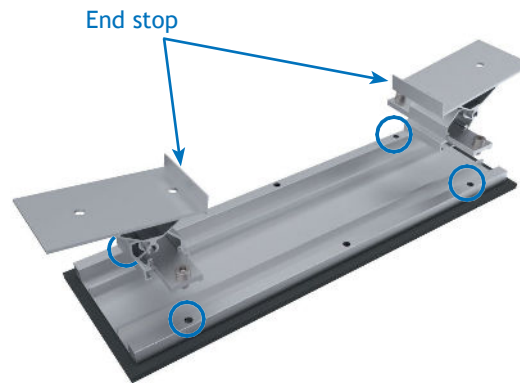

Make sure that the **end stop** on both raisers is facing **inwards** on the plate.

RAISED CENTRE LEG

Position each of the **large raisers** on the **outer holes** in the small plate. Apply **15 Nm** to tighten the hexagon socket bolt.

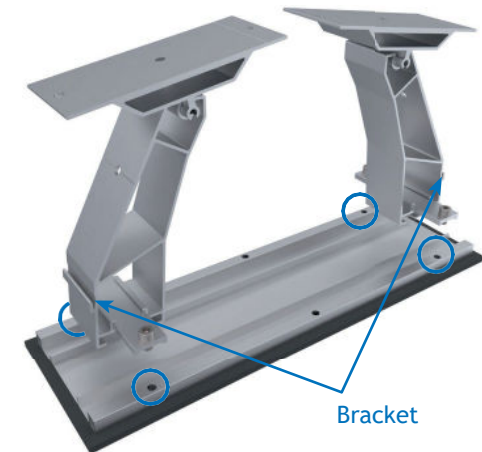

Make sure that the **bracket** on both raisers is facing **outwards** on the plate.

2

PRE-MOUNTING THE CLAMPS

If necessary, tighten the terminating and centre clamps with approx. **2 rotations** on the pre-mounted **raisers** of the **front and centre legs**.

TERMINATING & CENTRE CLAMP



FRONT LEG



RAISED CENTRE LEG



LOWERED CENTRE LEG

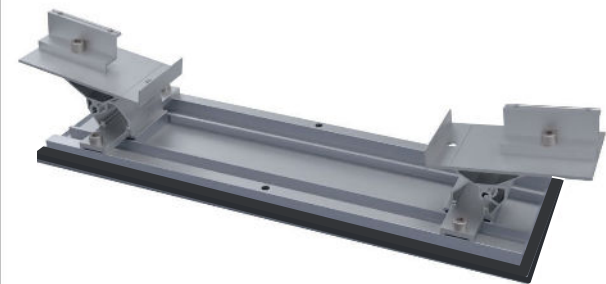

TIP: Check the orientation of the small and large raisers one more time.

MOUNTING DETAILS - EAST/WEST

1

POSITIONING OF THE LEGS

Position the module panels on the selected roof surface according to the ALUMERO project report.
To do so, measure the length and width of the module panel and position the **raised front and centre legs and the lowered central legs**.
The precise spacing between the legs depends on the length and width of the module.

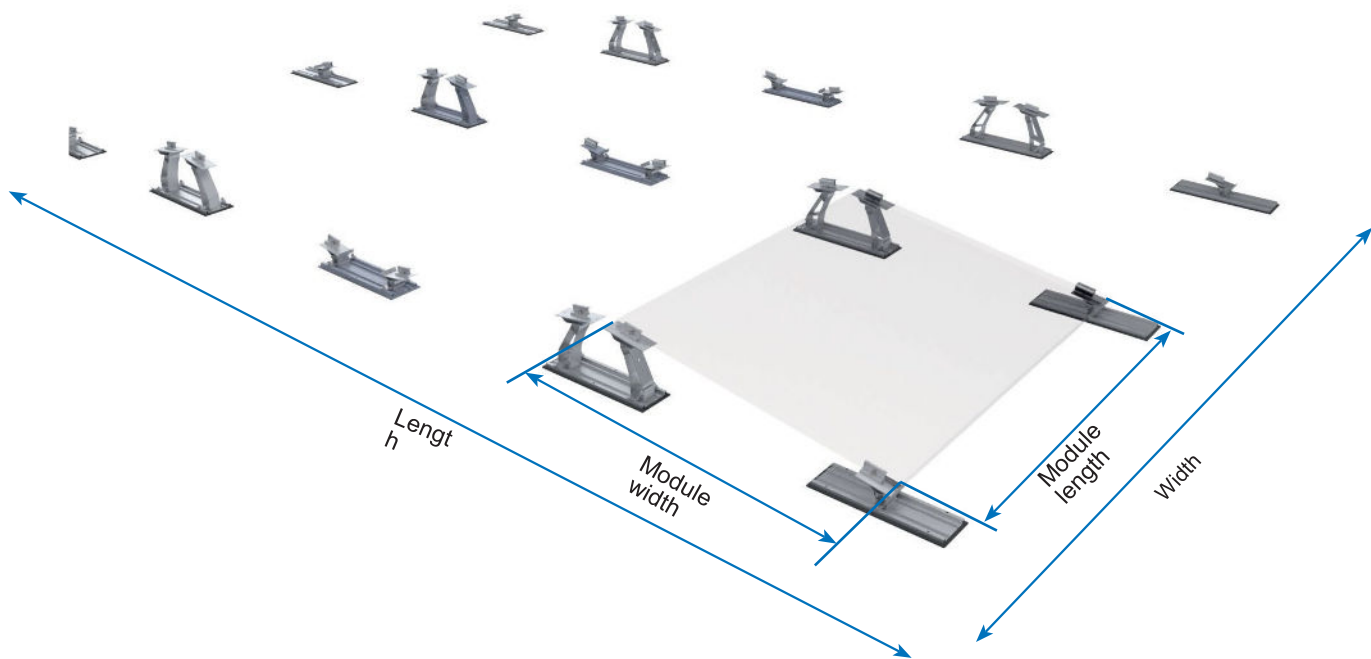

When positioning the legs, pay attention to the **end stop on the small raiser (Detail A)** and the **characteristic curve on the large raiser (Detail B)**.

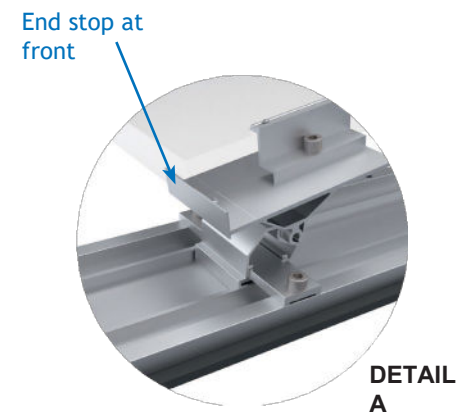

!

Use of the Alpine variant:

Caution! Pay attention to the positioning of the front and centre legs when using the **Alpine variant!** In this case the modules are positioned along the **characteristic curve of all legs**.

The procedure for mounting the **Alpine variant** is described from page 14 onwards.

2

MOUNTING THE MODULES

First module row:

Place the first module horizontally on the raised front and centre legs so that it is **flush** with the **end stop at the front of the small raiser** (Detail A) and the **characteristic curve at the rear of the large raiser** (Detail B).

Apply **15 Nm** to tighten the terminating clamps.

Push the next module onto the centre clamps of the previous module and apply **15 Nm** to tighten the centre clamps.

Mount the other modules in the same way.

Second module row:

Place the first module horizontally on the lowered and raised centre legs so that it is **flush** with the **end stop at the front of the small raiser** (Detail A) and the **characteristic curve at the rear of the large raiser** (Detail B).

Apply **15 Nm** to tighten the terminating clamps.

Push the next module onto the centre clamps of the previous module and apply **15 Nm** to tighten the centre clamps.

Mount the other modules in the same way.



If ballast trays are required, mount them before placing the second module row.

The procedure for mounting the ballast trays is described from page 25 onwards.

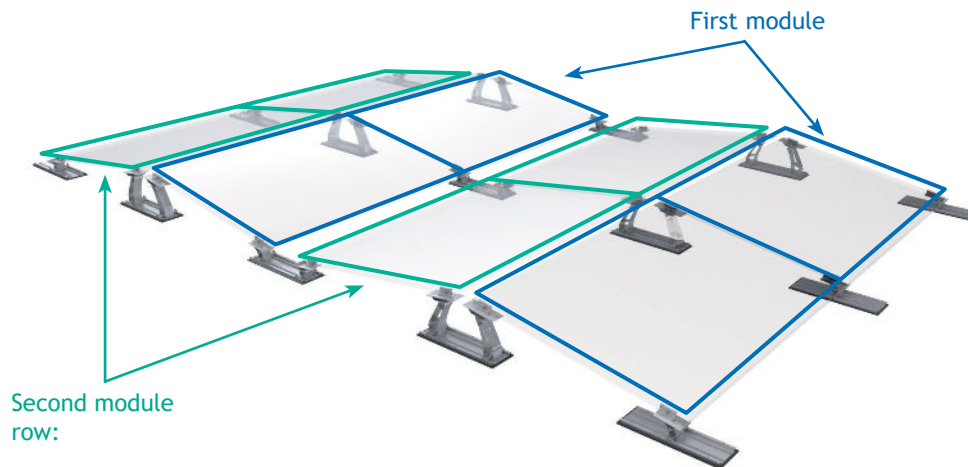

End stop at front

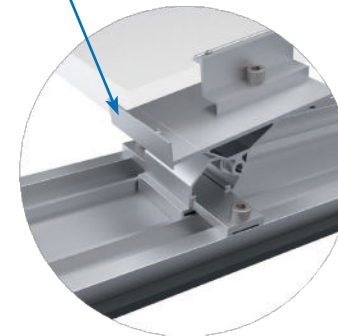

DETAIL A

Characteristic curve at rear



DETAIL B

OPTIONAL: ALPINE VARIANT - EAST/WEST

1

POSITIONING OF THE LEGS

Position the **module panels** as described on page 12.

MOUNTING THE ADDITIONAL LEGS

Attach additional **raised front and centre legs and lowered centre legs** to the middle of the module.

The sequence for module assembly is described on page 13.

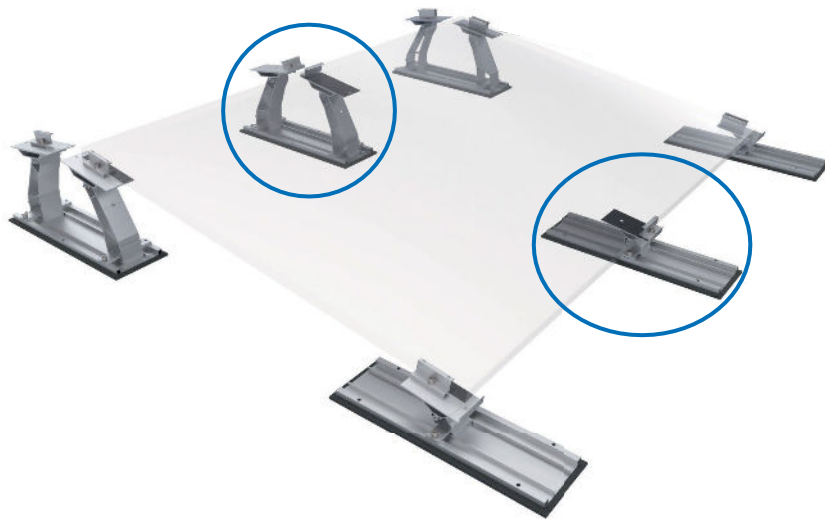

Make sure on all legs that the modules are positioned **flush** with the **characteristic curve on the small raiser** (Detail A) and the **characteristic curve on the large raiser** (Detail B).

Caution! Do not use the end stop on the small raiser!

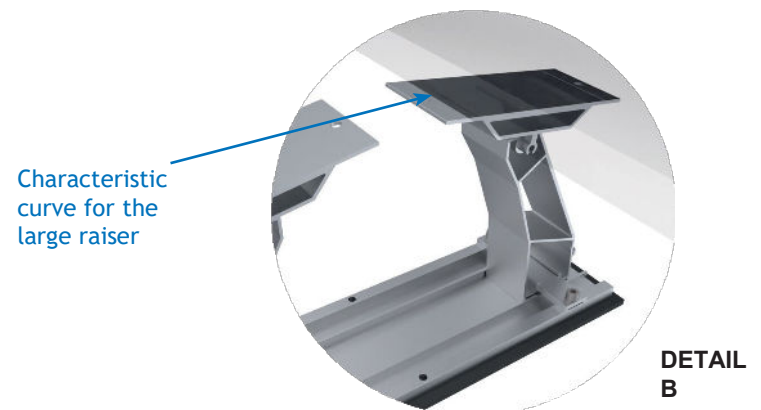
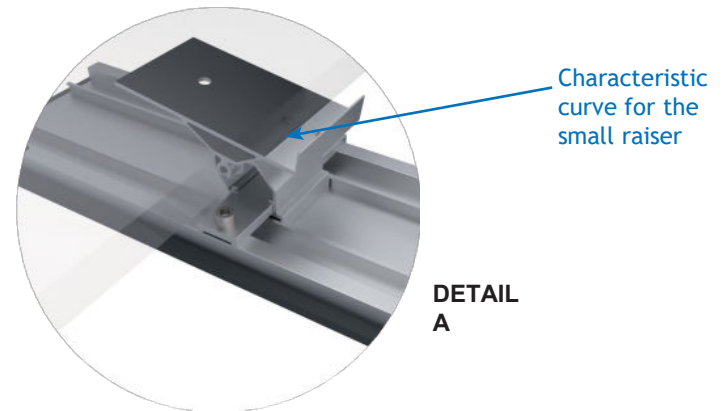

2

MOUNTING ADDITIONAL TERMINATING CLAMPS

Screw the additional **terminating clamps** into the pre-mounted raisers of the Alpine legs. Apply **15 Nm** to tighten them.

Terminating clamp for
the small raiser

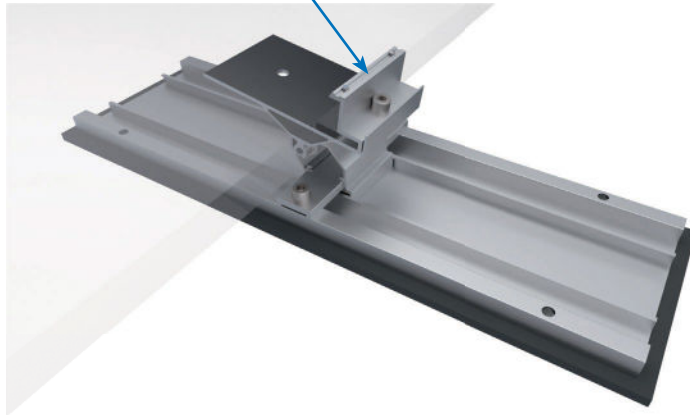

Terminating clamp for
the large raiser

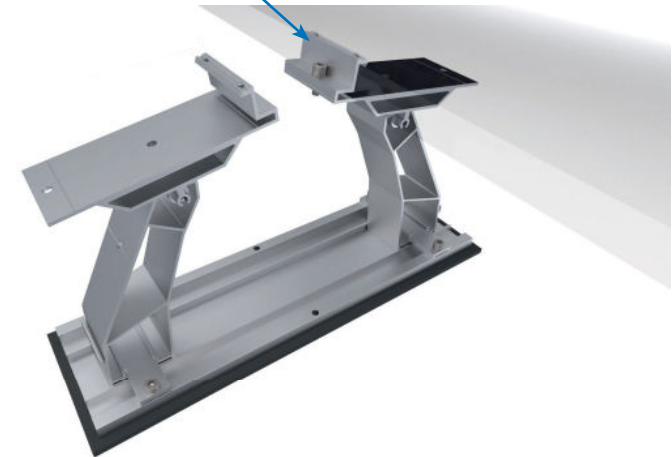

ASSEMBLY - SOUTH 18° /25°

1

FRONT LEG

Position the **small raiser** on the **central holes** of the small plate.
Apply **15 Nm** to tighten the pre-mounted hexagon socket bolt.

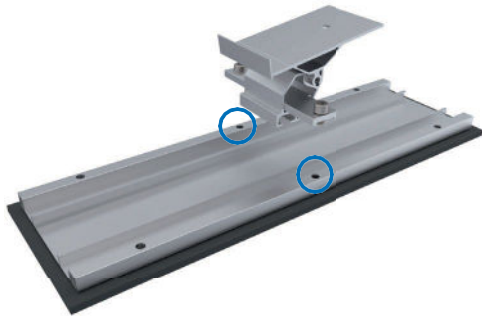

REAR LEG

Position the **large raiser** on the **central holes** of the small plate.
Apply **15 Nm** to tighten the pre-mounted hexagon socket bolt.



CENTRE LEG - SHADING ANGLE 18°

Position the **large raiser** on the **outer holes** on the left-hand side of the large plate.
Apply **15 Nm** to tighten the pre-mounted hexagon socket bolt.

Position the **small raiser** on the **outer holes** on the right-hand side of the large plate.
Apply **15 Nm** to tighten the pre-mounted hexagon socket bolt.

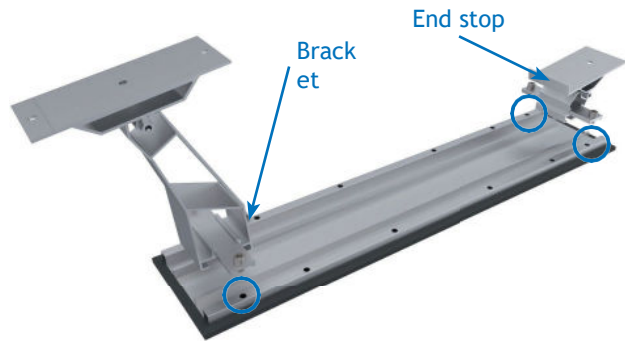

Make sure that the **bracket** for the large raiser and the **end stop** for the small raiser are each pointing towards the **inside** of the large plate.

CENTRE LEG - SHADING ANGLE 25°

Position the **large raiser** on the **second** of the outer **holes** on the left-hand side of the large plate.
Apply **15 Nm** to tighten the pre-mounted hexagon socket bolt.

Position the **small raiser** on the **second** of the outer **holes** on the right-hand side of the large plate.
Apply **15 Nm** to tighten the pre-mounted hexagon socket bolt.

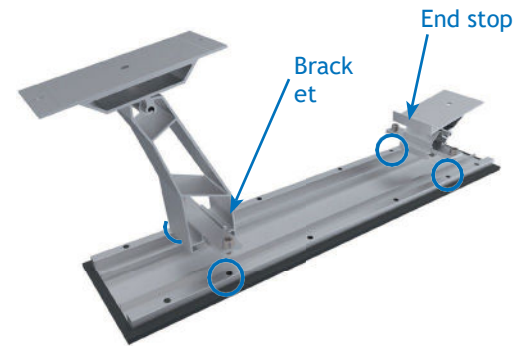

Make sure that the **bracket** for the large raiser and the **end stop** for the small raiser are each pointing towards the **inside** of the large plate.

2

PRE-MOUNTING THE CLAMPS

If necessary, tighten the terminating and centre clamps with approx. **2 rotations** on the pre-mounted **raisers** of the **front, rear and centre legs**.

TERMINATING & CENTRE CLAMP



FRONT LEG



CENTRE LEG



REAR LEG



TIP: Check the orientation of the **small and large raisers** one more time.

MOUNTING DETAILS - SOUTH

18° / 25°

1

POSITIONING OF THE LEGS

Position the module panels on the selected roof surface according to the ALUMERO project report. To do so, measure the length and width of the module panel and position the **front, centre and rear legs**. The precise spacing between the legs depends on the length and width of the module.

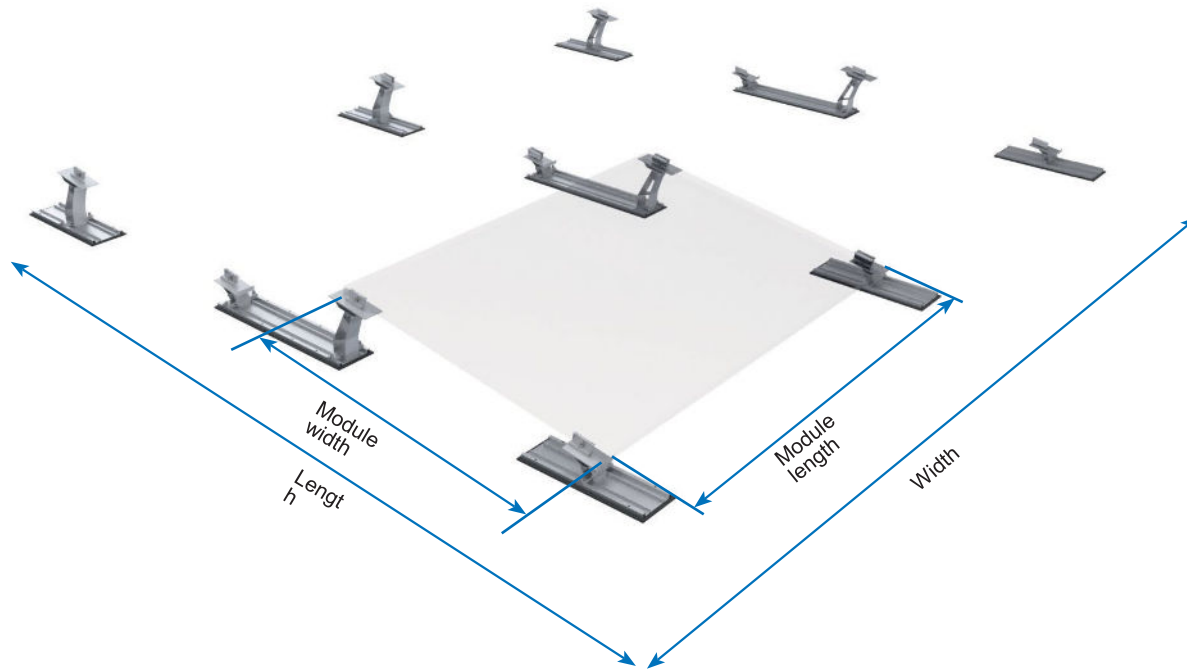

When positioning the legs, pay attention to the **end stop on the small raiser** (Detail A) and the **characteristic curve on the large raiser** (Detail B).

End stop at front

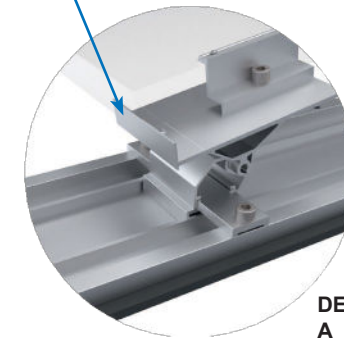

DETAIL A

Characteristic curve at rear

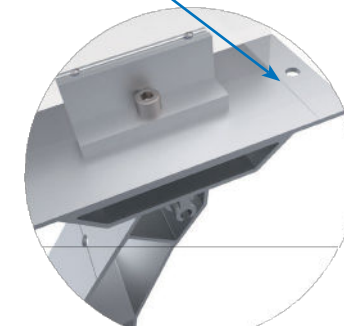

DETAIL B

Use of the Alpine variant:

Caution! Pay attention to the positioning of the front and centre legs when using the **Alpine variant!** In this case the modules are positioned along the **characteristic curve of all legs**.

The procedure for mounting the **Alpine variant** is described from page 21 onwards.

2

MOUNTING THE MODULES

First module row:

Place the first module horizontally on the front, centre and rear legs so that it is **flush with the end stop at the front of the small raiser (Detail A)** and the **characteristic curve at the rear of the large raiser (Detail B)**.

Apply **15 Nm** to tighten the terminating clamps.

Push the next module onto the centre clamps of the previous module and apply **15 Nm** to tighten the centre clamps.

Mount the other modules in the same way.

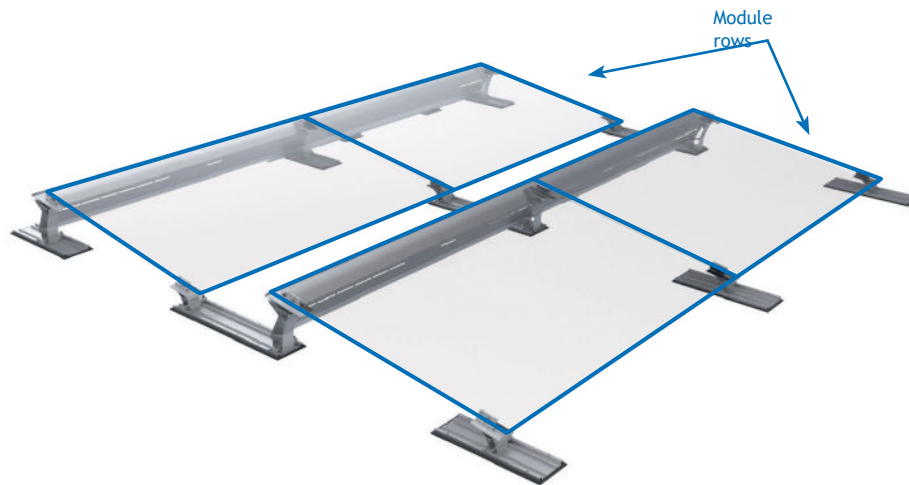

End stop at front

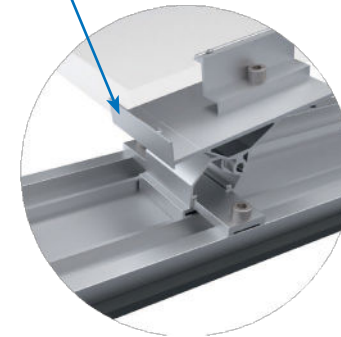

DETAIL
A

Characteristic curve at rear

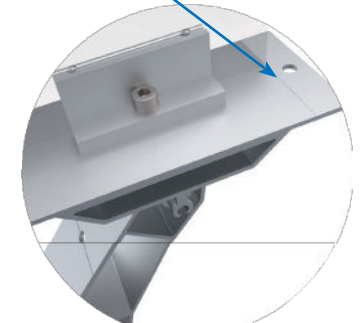

DETAIL
B

OPTIONAL: ALPINE VARIANT - SOUTH 18° /25°

1

POSITIONING OF THE LEGS

Position the **module panels** as described on page 19.

MOUNTING THE ADDITIONAL LEGS

Attach additional **front, centre and rear legs** to the middle of the module.

The sequence for module assembly is described on page 20.

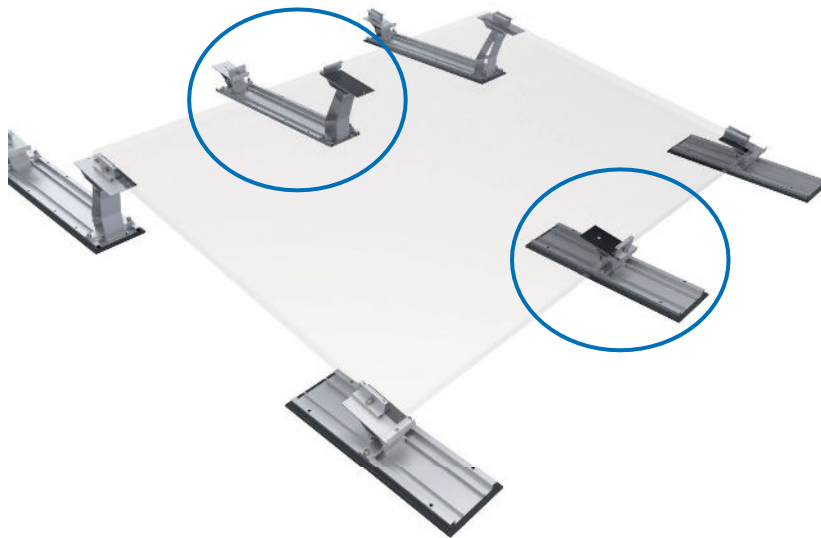

Make sure on all legs that the modules are positioned **flush** with the **characteristic curve on the small raiser** (Detail A) and the **characteristic curve on the large raiser** (Detail B).

Caution! Do not use the end stop on the small raiser!

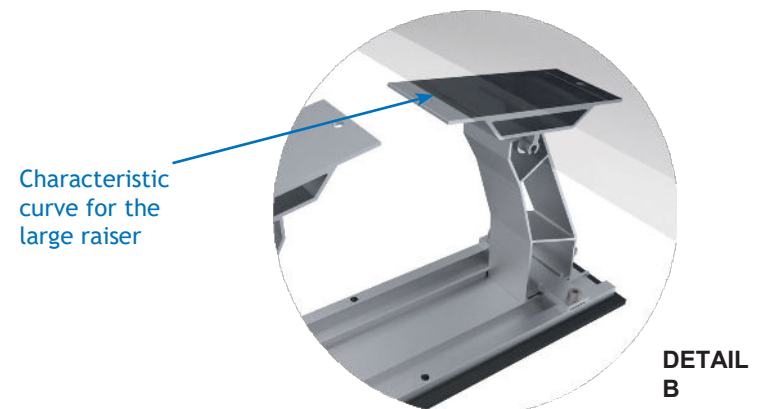
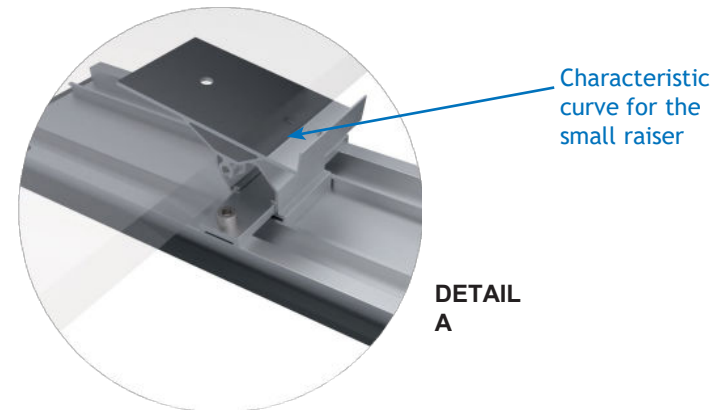

2

MOUNTING ADDITIONAL TERMINATING CLAMPS

Screw the additional **terminating clamps** into the pre-mounted raisers of the Alpine legs. Apply **15 Nm** to tighten them.

Terminating clamp for the small raiser

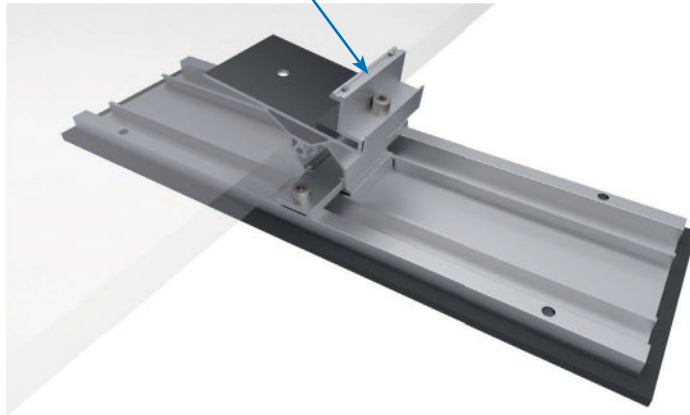

Terminating clamp for the large raiser

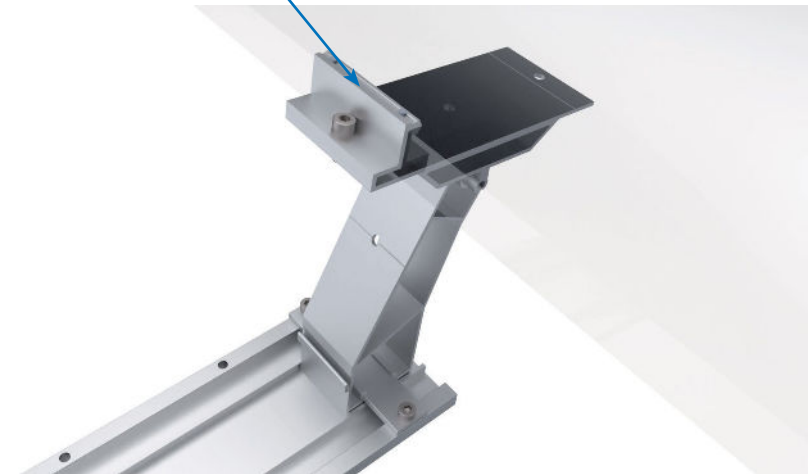

MOUNTING THE WIND DEFLECTOR PLATE - SOUTH 18/25°

1 INSERTING THE WIND DEFLECTOR PLATE INTO THE BRACKET

Place the wind deflector plates into the **brackets** of the large raisers on the centre and rear legs.

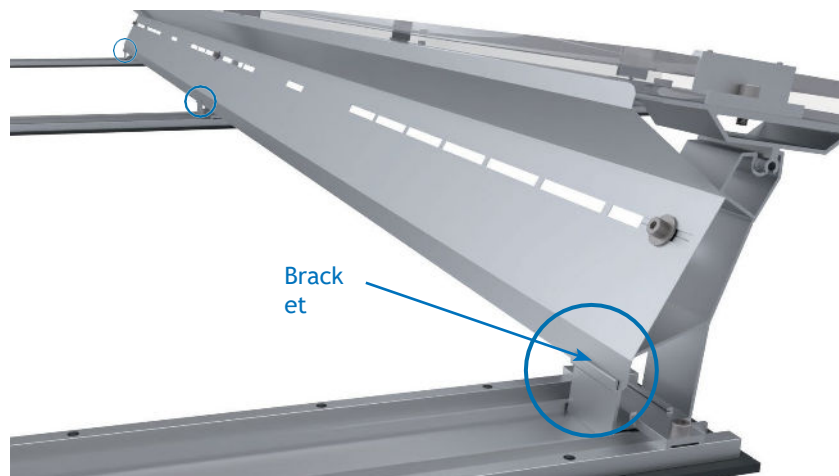

Make sure that the wind deflector plates are **flush with the adapters** of the centre and rear legs at the beginning and end of a module row.

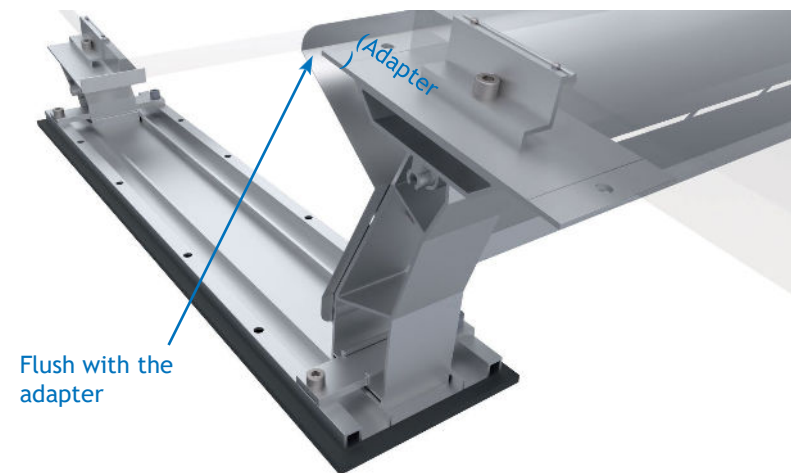

2

SCREWING THE WIND DEFLECTOR PLATE IN PLACE

Use washers and **hexagon socket bolts** to screw the wind deflector plates into the holes on the legs. Apply **15 Nm** to tighten them.



Wind deflector plates are mounted overlapping if they meet.

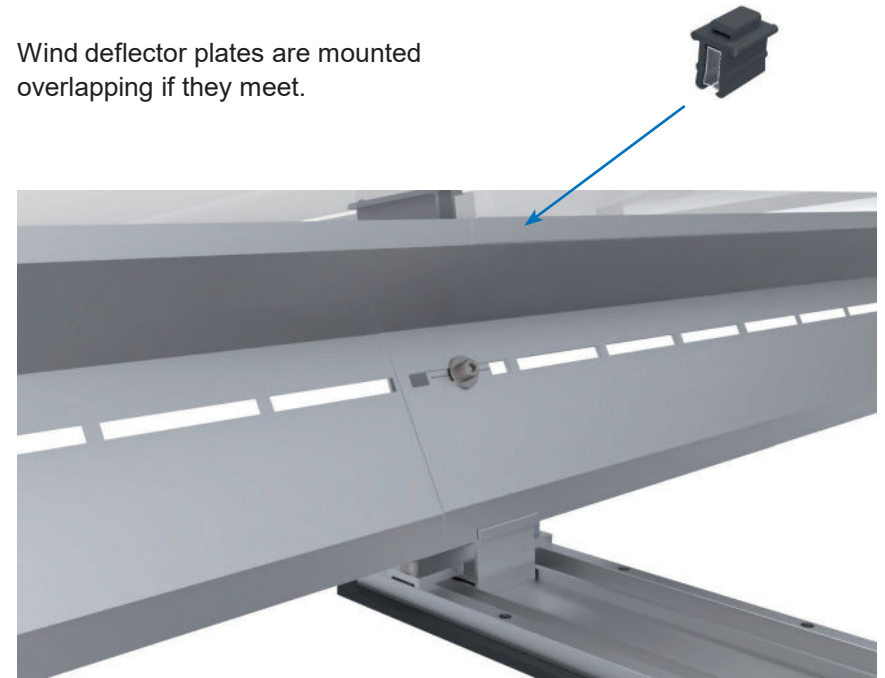

TIP: Additional clips should be attached where the wind deflector plates overlap.

MOUNTING THE BALLAST TRAYS

1

USE OF ADDITIONAL SHIMS

The **ballast trays** are mounted on the **small or large plates**, depending on the system.

Place **additional shims** under the ballast trays and attach them to the holes of the respective plates using washers and hexagon socket bolts.



The ballast trays are mounted on the various legs, e.g. the front, rear or centre legs, depending on the system.



Example

STANDARD VERSION

Use two shims per ballast tray for > 8 blocks or > 64 kg.

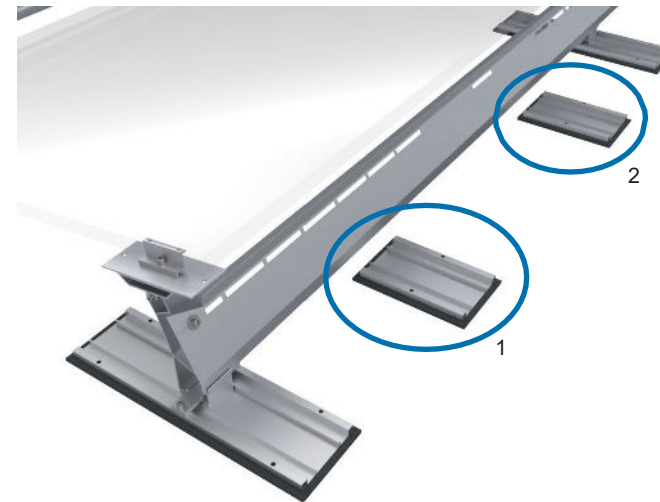

Only use one shim per ballast tray for < 8 blocks or < 64 kg.



ALPINE VERSION

Do not use any shims for < 8 blocks or < 64 kg, as the Alpine leg is pre-mounted in the centre.



Use two shims per ballast tray for > 8 blocks or > 64 kg.

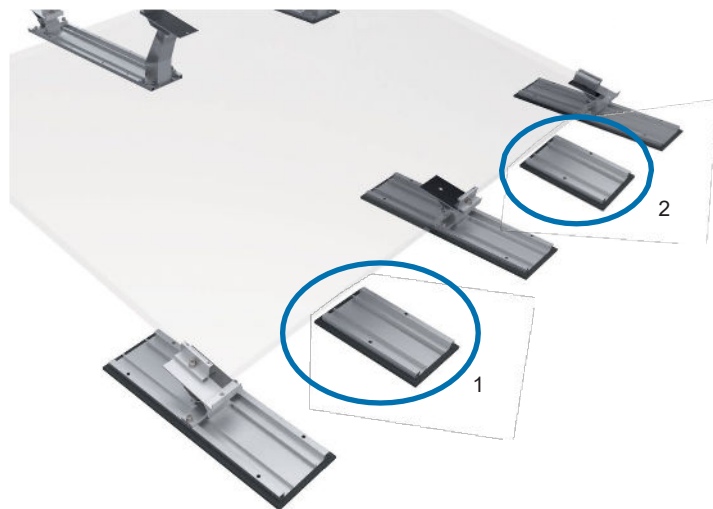

Example



The ballast trays are mounted on the various legs, e.g. the front, rear or centre legs, depending on the system.

BALLAST

Ballast is calculated for each project exclusively by means of the **MoSo-Solar.Pro.Tool**.

The number of blocks that are required to hold the system in place, and at which points, is calculated based on the dimensions and weight of the block.

Use **ballast trays** or the **ballast brace** to hold the blocks in place.

BALLAST TRAY

The blocks are placed directly into the ballast trays.



The project report contains a precise description of the number and positioning of the blocks.

BALLAST BRACE

The blocks can be positioned directly on the plates using ballast braces. Position each ballast brace on the edge of the block so that 3-point contact is established.

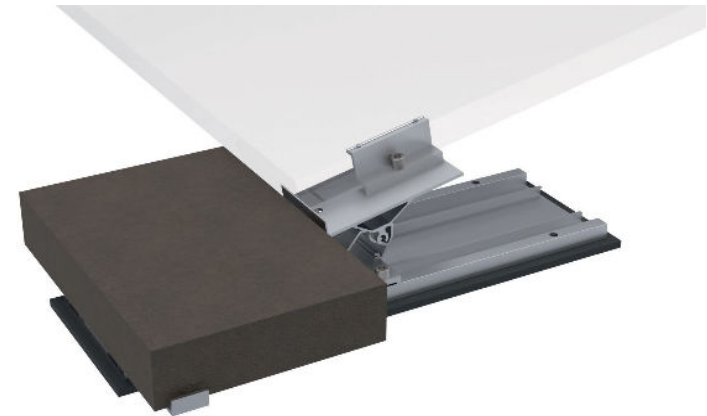
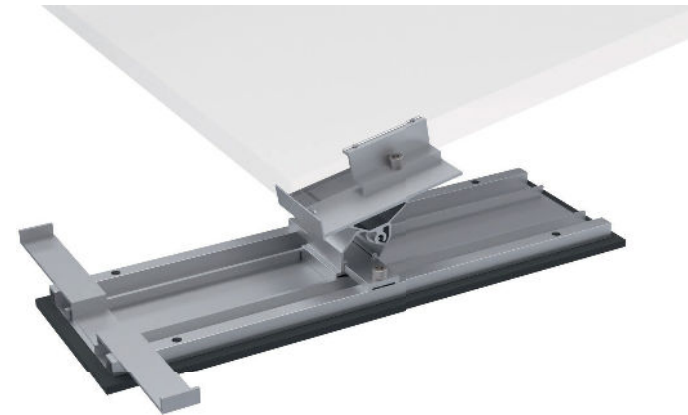

MOUNTING THE CABLE MANAGEMENT

Insert the module cable into the cable cover. (Fig. 1)

Position the cable cover on the edge of each plate so that it is flush with the plate and attach it to the holes in the plate using a hexagon socket bolt. (Fig. 2) Apply 15 Nm to tighten the hexagon socket bolt. (Fig. 3)

Fig. 1

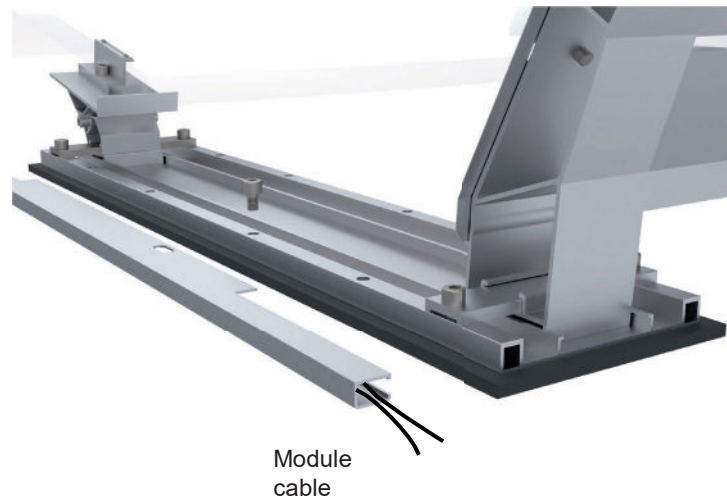

Fig. 2

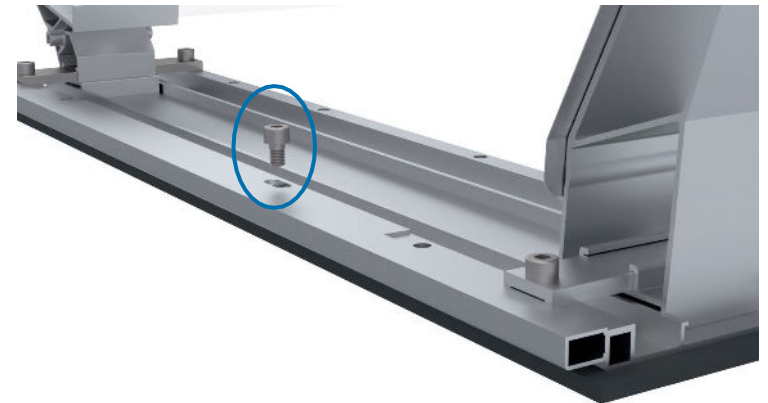

Fig. 3



PLEASE OBSERVE THE FOLLOWING INSTRUCTIONS!

We recommend that you read these instructions carefully as they are very important for product handling. Please also inform yourself about the safety regulations for the other system components.

SAFETY AND WARNING INSTRUCTIONS

The pitched roof system easySPEED 1 is designed exclusively for mounting PV modules. Any other form is considered improper use. Proper use also includes adherence to the information contained in these mounting instructions. ALUMERO is not liable for damage caused by non-compliance with the mounting instructions, in particular the safety instructions, or from misuse of the product.

- + ALUMERO accepts no liability whatsoever for any loss of performance or damage to the modules.

You must adhere strictly to these instructions when performing any work on the PV system. Installation, commissioning, maintenance and repair may only be carried out by persons who are suitably qualified and authorised.

Please observe the valid regulations and safety instructions.

You must adhere to the following accident prevention regulations:

- + BGV A1 - General provisions
- + BGV A3 - Electrical installations and equipment
- + BGV C22 - Construction work (Personal protective equipment against falls from a height)
- + BGV D36 - Ladders and steps
- + Employers' liability insurance association rules for safety and health at work BGR 203 (roof work) and DIN EN 516 Prefabricated accessories for roofing
- + Provisions on work apparel and health and safety according to the regulations of the employers' liability insurance association.

You must adhere to the following DIN standards:

- + DIN 18299 - General rules applying to all types of construction work
- + DIN 18338 - Roofing and roof waterproofing works
- + DIN 18360 - Metal construction works, locksmith works
- + DIN 4102 - Fire behaviour of building materials and building components

All work on the ALUMERO systems may only be carried out by authorised persons. The system operator has the following obligations that affect safety:

- + We require an inspection and maintenance to be performed at least once a year on the installed components of the pitched roof system easySPEED 1 and the roof cladding. This should include checking at least the following points:
 - » correct fit and tightness of all mechanical connections
 - » and deformation of the system position on the roof or of the system itself
 - » flawless condition of the wiring
 - » damage to the PV modules
- + The frame may only be mounted by persons with suitable qualifications, manual skills and basic knowledge of mechanics.
- + It must be ensured that the persons assigned to the work are able to assess the tasks entrusted to them and to identify potential dangers.
- + The mounting instructions are an integral part of the product and must be available during mounting.
- + It must be ensured that the persons assigned to the work have read and understood the mounting instructions and in particular the safety instructions prior to mounting.
- + The regulations of the employers' liability insurance association, the local occupational health and safety regulations and the rules of engineering must be adhered to.
- + Suitable lifting equipment and ladders must be used during mounting. The use of straight ladders is prohibited.
- + A specialised construction engineer must check the building statics to ascertain the additional load of the PV system.
- + Any general load limitations imposed by ALUMERO GmbH (e.g. snow clearance requirement to limit the snow load) must be taken into account.



WARRANTY/PRODUCT LIABILITY (DISCLAIMER)

The dimensioning information contained in these instructions merely reflects practical experience. The MoSo-Solar.Pro.Tool program can be used to prepare binding mounting frame statics.

As an installation firm, you are responsible for ensuring that mounting is performed correctly. ALUMERO Mounting Solutions GmbH is not liable for dimensioning information contained in commercial system quotes.



As an installation firm, you are responsible for the mechanical durability of the installed port connections on the building envelope and for their tightness in particular. The components from ALUMERO are designed for the anticipated loads and according to the current state of the art. For this purpose, you must notify ALUMERO in writing of all general technical conditions (information concerning the support structure, snow load zone, building heights, wind loads, etc.) in your enquiry/order.

ALUMERO shall not be liable if the mounted components are handled improperly. The systems must not be mounted close to the sea due to the risk of corrosion.

ALUMERO grants a 2-year product warranty on the service life and durability of the rack systems, provided they are handled properly, dimensioned correctly to suit the general statics and exposed to normal environmental and ambient conditions. This applies to the prevailing weather and environmental conditions in particular.

Warranty on material and workmanship: ALUMERO extends a 25-year material and workmanship warranty on all used materials. Refer to the separate warranty terms for more information.

INSTRUCTIONS FOR ELECTRICAL INSTALLATION



You may only perform electrical works if you are a qualified electrician. The applicable DIN standards, VDE regulations, VDEW guidelines, VDN guidelines, accident prevention regulations and regulations of the local electricity supply companies are authoritative in this regard.

- + DIN VDE 0100 (Erection of power installations with rated voltages below 1000)
- + VDEW Guideline - Parallel operation of self-generating systems with the low-voltage grid of the electricity supply company
- + VDI 6012 Guideline - Integration of decentralised and regenerative energy systems in buildings: Photovoltaics
- + Leaflet on the VDEW Guideline "Self-generating systems in the low-voltage grid"
- + VDN Guideline "Self-generating systems in the low-voltage grid"
- + DIN/VDE regulations, DIN/VDE 0100 "Erection of power installations with rated voltages below 1000", in particular VDE 0100 Part 410 "Protection against direct and indirect contact" (DC voltages > 120 V, < 1000 V DC) and the "Accident prevention regulation of the industrial employers' liability insurance associations" VBG4 "Electrical installations and equipment".
- + DIN VDE 0100-540 Selection and erection of electrical equipment - Earthing arrangements and protective conductors
- + VDE 0185 Installation of a lightning protection system and VDS 2010

IMPORTANT WARNING INSTRUCTIONS



Solar modules generate electricity as soon as they are exposed to light, which means that they are always live. Although the fully insulated plug contacts offer contact protection, you must pay attention to the following when handling the solar modules:

- + Do not insert any electrically conductive parts into the plugs and sockets.
- + Do not mount solar modules and cables if the plugs and sockets are wet.
- + Always exercise great care when working on the cables.
- + Never perform any electrical installation in damp conditions.
- + Very high direct voltages occur at the series connection of solar modules - even with low illumination - which are potentially fatal when touched. Pay particular attention to the possibility of secondary damage in the event of electric shocks.



High contact voltages may occur in the inverter, even when disconnected:

- + Exercise particular care when working on the inverter and the cables.
- + Make sure that you observe the time intervals specified by the manufacturer between switching off the inverter and carrying out further work so that the high-voltage components can discharge.
- + Please also adhere to the mounting instructions issued by the inverter manufacturer.

A fatal flashover may occur when opening a closed string (e.g. when disconnecting the DC line from the live inverter):

- + Never disconnect the solar generator from the inverter while it is connected to the grid.



STANDARDS AND GUIDELINES

All listed standards and guidelines are issued and applicable for Germany. Their most recent version must be consulted. In addition, adhere to the national standards and guidelines when mounting the systems outside of Germany.

INSTRUCTIONS FOR FRAME INSTALLATION

You must observe the currently applicable rules of construction technology, in particular the requirements set out in the DIN standards and the “Rules and Regulations of the German Roofing Trade” for mounting in the roof area.



- + Check that all screw connections are tightened properly.
- + Adhere to the specified torques.
- + Besides obtaining a verifiable structural analysis, you must make sure that the product meets the local structural requirements according to DIN EN 1991 before it is mounted.
- + DIN standard EN 1991 “Actions on structures” - and all associated national application documents
 - » Part 1-1: Densities, self-weight, imposed loads for buildings
 - » Part 1-3: Snow loads
 - » Part 1-4: Wind loads
- + DIN standard EN 1990: “Basics of structural design” - and all associated national application documents
- + The mounting frame is designed in accordance with DIN EN 1993 “Design of steel structures” and DIN EN 1999 “Design of aluminium structures”.
- + Make sure that the load-bearing capacity (dimensioning, condition, material parameters), load-bearing structure and other affected layers (e.g. insulation layer) of the substructure is suitable.
- + Make sure that the drainage of precipitation is not obstructed.
- + Take aspects of building physics into account (e.g. possible condensation when making holes in insulation layers).



PRODUCT LIABILITY

The technical documentation is an integral part of the product. ALUMERO is not liable for damage caused by non-compliance with the mounting instructions, in particular the safety instructions, or from misuse of the products.

The logo for ALUMERO is a black-outlined, horizontally-oriented oval shape with a slight curve at the top and bottom. Inside this shape, the word "ALUMERO" is written in a bold, black, sans-serif font.

ALUMERO

ALUMERO Mounting Solutions GMBH
Eugen Getzner Straße 7 | 6710 Nenzing | Austria

P +43 5525 93082 | office.ms@alumero.at